

REVISION HISTORY

| REV | DESCRIPTION | DATE | APPROVED |
|-----|-------------|------|----------|
| | | | |

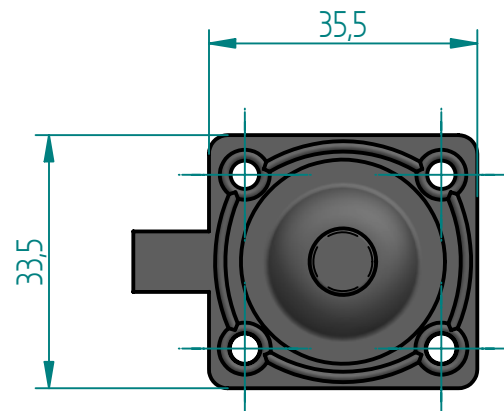
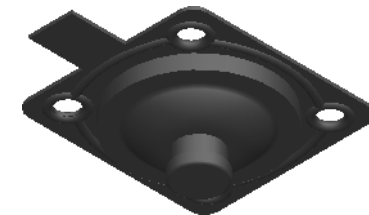
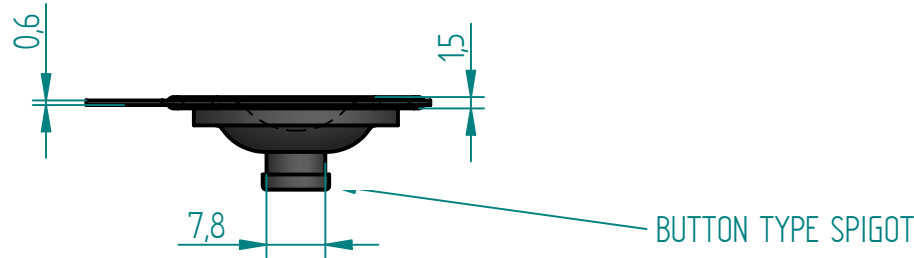
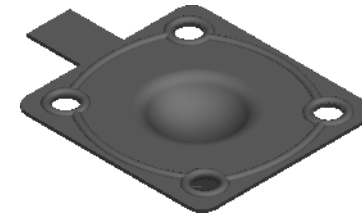
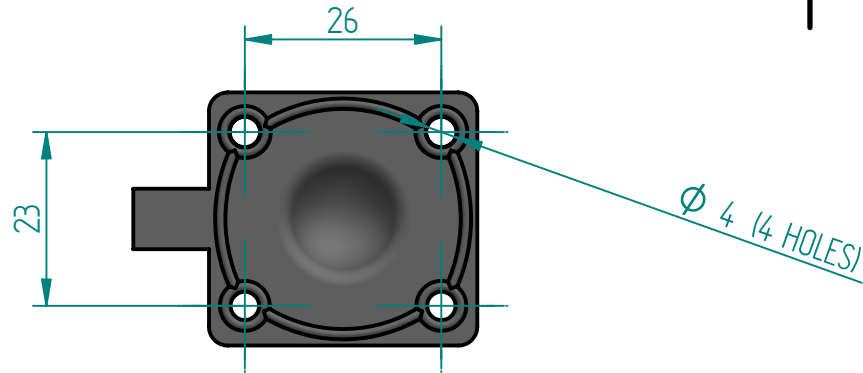

Replacement Diaphragm for :-

Grade : FPM/FKM – FDA

USED ON 1/4", 3/8", 1/2" (DN8,10,15,) Diaphragm Valve

| | NAME | DATE |
|---------|-----------|----------|
| DRAWN | M.MC KEON | 01/21/15 |
| CHECKED | | |



Material - FPM/FKM

TITLE **DD03-SFPM**

FDA Compliance :
21 CFR 177.2600

SIZE A **FOOT PRINT DIMENSIONS** REV B

FILE NAME: DD03-SFPM.dft

SCALE: 1 : 1 ECO:0605 SHEET 1 OF 1

Disclaimer - Diaphragm Direct® does not manufacture, represent, nor sell OEM valves or diaphragms manufactured by any other company. Diaphragm Direct® brand diaphragms are not sponsored by any other manufacturers. Any name, model, part number, brand, image, material or referral is for descriptive purposes only. Diaphragm Direct® brand replacement diaphragms are guaranteed to fit OEM equipment and meet or exceed OEM specifications. Diaphragm Direct® brand replacement diaphragms are covered by the standard Diaphragm Direct® limited product warranty.